

Aggie Code of Honor: Aggies do not lie, cheat or steal, nor tolerate those who do.

CHARLIE NOBLE



Texas Maritime Academy
Texas A&M University at Galveston

O-Week • August 2010

Aggie Code of Honor: Aggies do not lie, cheat or steal, nor tolerate those who do.

AGGIE CODE OF HONOR

Aggies do not lie, cheat or steal,
nor tolerate those who do..



Aggie Code of Honor: Aggies do not lie, cheat or steal, nor tolerate those who do.



Aggie Code of Honor: Aggies do not lie, cheat or steal, nor tolerate those who do.

WELCOME ABOARD!

Welcome to the Texas Maritime Academy (TMA) at Texas A&M University at Galveston. Texas A&M University is over a century old with traditions forged by thousands of Mariners, Sailors, Marines and Soldiers who are proud to be called Aggies.

After O-Week, you will participate in the daily routine of the Cadet Battalion. Your success or failure will depend on how well you adjust to this new way of life. The profession for which you are preparing requires leadership, responsibility, and professional knowledge. Your active participation in the Batt system and the development of good study habits will ensure your success here and in the future.

When you graduate from the Texas Maritime Academy, you will be a member of an elite group. You will have a bachelor's degree, a United States Coast Guard Third Mate or Third Assistant Engineer's license and may be eligible for a reserve commission in the United States Armed Forces.

The record that you compile here will remain with you forever. You will be judged by it many times. Texas A&M University at Galveston and the Texas Maritime Academy will give you the opportunity to develop leadership skills, understand the importance of being part of a team and most of all the importance of academic achievement!

Aggie Code of Honor: Aggies do not lie, cheat or steal, nor tolerate those who do.

**TEXAS A&M UNIVERSITY AT GALVESTON
TEXAS MARITIME ACADEMY
PURPOSE STATEMENT**

The Texas Maritime Academy (TMA) is a prestigious, highly-specialized maritime training and education program embedded within Texas A&M University at Galveston (TAMUG), a branch campus of Texas A&M University (TAMU). The mission of TMA is to provide the maritime industries of the State of Texas and the United States with highly-trained and professional U.S. Coast Guard **licensed Merchant Officers** (Deck/Engine) to serve on ocean-going and inland waterway vessels.

Cadets who qualify may volunteer through the Naval Science Department and the Naval Reserve Officers Training Corps (NROTC) program to be commissioned to serve in the **Merchant Marine Reserve (MMR) program**. Cadets may also choose to request an active duty commission in the U.S. Navy or a direct commission in the U.S. Coast Guard.

NROTC—NROTC Cadets also gain valuable skills, learning leadership experience from a Navy perspective. This includes taking a Naval Science course each semester, participating in drills at least once a week, and wearing your Navy uniform. Another highlight for NROTC students is Summer Cruise Training. Your Summer Cruise Training will not only give you on-the-job experience as a Navy Officer, but prepare you for an officer's career in the US Navy.

Drill and Ceremonies (D&C) - Cadets who are not in the LO or NROTC programs but desire to be exposed to the leadership training, spirit, and camaraderie of Battalion life.

Victor Company—For those cadets who live off campus. Must be over 25 yrs, or married, or veteran or completed your degree, or live with your parents.

Aggie Code of Honor: Aggies do not lie, cheat or steal, nor tolerate those who do.

TEXAS A&M UNIVERSITY PURPOSE STATEMENT

To develop leaders of character dedicated to serving
the greater good.

Our purpose statement carries with it the responsibility, the traditions and the forward thinking of Texas A&M University exemplified by all who are associated with the university — its faculty and staff, and its current and former students. This can be defined by six core values.

Excellence - Set the bar.

"Excellence stems from a great sense of pride in who we are and what we believe in." -Former Texas A&M president, Dr. Robert Gates

Integrity - Character is destiny.

"The Aggie Code of Honor which Aggies recite by heart: Aggies do not lie, cheat or steal nor tolerate those who do" shows what goes to the heart of being an Aggie." - Texas A&M Leadership

"Integrity was the core value that A&M gave me more of than any other. It helped me succeed in my career because my fellow professionals, clients and friends knew that they could rely on me and my word." - Former Student

Leadership - Follow me.

"The spirit of leadership is instilled in every student - whether they go on to lead in the boardroom or in the backyard - they have the values, the confidence and the experience to lead change in their world." - Texas A&M Leadership

Aggie Code of Honor: Aggies do not lie, cheat or steal, nor tolerate those who do.

Loyalty - Acceptance forever.

Through unity, strength. - Texas A&M University Corps of Cadets Motto

"Loyalty and respect for tradition is about a sense of belonging to something greater than yourself. You're a part of a history of traditions...of a larger community." - Former Executive Vice President and Provost, Dr. David Prior

Respect - We are the Aggies, the Aggies are we.

"A&M students aren't just joining a university, they're joining a lifelong family that understands the value of loyalty, camaraderie, and unconditional support." - Texas A&M Leadership

Selfless Service - How can I be of service?

"A&M encourages volunteerism, encourages being one of a thousand points of light, helping others...and it comes naturally to Aggies." - Former US President, George Bush (41)

Aggie Code of Honor: Aggies do not lie, cheat or steal, nor tolerate those who do.

CHAIN OF COMMAND

In order to ensure the smooth operation of the Texas Maritime Academy, a chain of command has been established. The Cadet leaders' or Battalion staff's function is to handle problems that affect the Corps as a whole. With this policy, most problems can and will be handled within a squad, platoon, or company. For example, a squad member, squad leader, a chief petty officer, etc. would not approach a member of Battalion-staff with a problem. They would approach the next highest person in their chain of command who would in turn do the same. This would continue until the problem was solved or reached the company commander who is the liaison to the Battalion staff. The chain of command is as follows:

Command of the Cadet Battalion

Battalion Commander (CO)
Battalion Executive Officer (XO)
Battalion Adjutant
Battalion Master-at-Arms (MAA)

Command of a Company

Company Commander
Company Executive Officer
Platoon Leaders

In addition to the chain of command, there are several other Cadet staff positions within the Texas Maritime Academy Cadet Battalion.

Quartermaster
Deck Training Officer
Engine Training Officer
Academic Affairs Officer
Public Affairs Officer
Drill Team Officer
Waterfront Officer
Chaplain

Aggie Code of Honor: Aggies do not lie, cheat or steal, nor tolerate those who do.

TEXAS MARITIME ACADEMY

Administrative Chain of Command

Rear Admiral William W. Pickavance Jr., USN (ret.)
Superintendent

Colonel Richard A. Mallahan, USAF (ret.)
Commandant

LT Carlos Traveria, TMA
Cadet Training Officer

SFC Claude Davidson, US Army (ret.)
Assistant to the Commandant

Battalion Staff

Company Staff

Cadet Battalion

Aggie Code of Honor: Aggies do not lie, cheat or steal, nor tolerate those who do.

Operational Chain of Command

Rear Admiral William W. Pickavance Jr., USN (ret.)
Superintendent

Captain Jack H. Smith, USMS
Captain/ Master of the Ship

Captain Henry Fredrickson, USMS
Chief Engineer

Deck

Captain Jack H. Smith, USMS
Master

Captain Leslie J. Blackburn III
Chief Mate

Boatswain

Engine

Captain Henry Fredrickson, USMS
Chief Engineer

Commander Charlie Cesari, USMS
1st Assistant Engineer

Lieutenant Commander Larry Splawn, USMS
2nd Assistant Engineer

Aggie Code of Honor: Aggies do not lie, cheat or steal, nor tolerate those who do.

Faculty

Captain Jack H. Smith, USMS – MART

Captain John Lane, USMS – MART

Captain Karl H. Haupt, USMS – MART

Captain Michael Miller, USMS – MART

Captain Robert L. Thrailkill, USMS – MART

Captain Augusta D. Roth, USMS – MART

CDR Gerard Coleman, USN (ret.) – MARE

Captain Vincent Treglia, USMS – MARE

MART = Marine Transportation

MARE = Marine Engineering Technology

Counseling Services

Counseling Services are available through the office of Student Counseling located in the Mary Moody Northern Student Center Suite 108. Office hours are Monday through Friday 8 a.m. to 5 p.m. The office number is (409) 740-4736 or afterhours emergency (through the University Police Department) (409) 740-4545. E-mail studentservices@tamug.edu.

www.tamug.edu/counsel

Aggie Code of Honor: Aggies do not lie, cheat or steal, nor tolerate those who do.

DAILY ROUTINE

During orientation week, your daily routine is dictated by the orientation schedule and by the O-Week Officers.

During the school year, formations will be held Monday through Friday at 0745, and unannounced room inspections will be held weekly at the discretion of the Commandant.

You are required to attend Corps Activity training (Z OPT) as determined by the Ship's Captain and Chief Engineer. This may include Saturday training sessions scheduled for your company. All TMA cadets will perform watch duty on the Academy Ship throughout the school year.

SOUNDING OFF

When identifying oneself or when ordered to sound off, a fish will reply as follows:

"Howdy, Sir/Ma'am, fish, your last name, Sir/Ma'am!"

ORDERS AND QUESTIONS

When a fish does not know the answer to a question that an upperclassman asks, the fish will reply, as rapidly as possible:

"Sir/Ma'am, not being informed to the highest degree of accuracy, I hesitate to articulate for the fear that I may deviate from the true course of rectitude. In short, Sir/Ma'am, I am a very dumb fish and do not know, Sir/Ma'am!"

GENERAL RESPONSE

"Aye Aye, Sir/Ma'am," is used by nautical personnel to say an order is understood. The word "right" is never used as it could cause confusion on a bridge. When in doubt—always err on the side of courtesy.

Aggie Code of Honor: Aggies do not lie, cheat or steal, nor tolerate those who do.

MILITARY COURTESIES

All Cadets will recognize members of TAMUG with a "Howdy" as they pass.

All Cadets will recognize professors and staff members with a "Howdy, Sir/Ma'am."

All Cadets will salute military and merchant marine officers (whether in or out of uniform) and will say "Howdy, Sir/Ma'am."

All Cadets will stand when a Professor or Officer walks into a classroom or meeting.

All Cadets will be called to attention in large meetings. A Cadet will be posted by the door and say "Attention on Deck."

All Cadets will rise and be at attention when colors pass indoors. If covered or outside they will salute.

All Cadets will pay proper respect to colors.

All Cadets will rise for benedictions and invocations.

All Cadets will conduct themselves as ladies and gentlemen in the tradition of Texas A&M.

Aggie Code of Honor: Aggies do not lie, cheat or steal, nor tolerate those who do.

BASIC UNIFORM REGULATIONS

- Uniforms will be worn in accordance to uniform regulations and as directed by the Commandant and Corps Commander.
- Covers will only be worn outside or under arms. They will be square on the head, with approximately two fingers distance between the bill, brim, or front of the cover and the base of the forehead.
- The gig line will be straight.
- Shirts will be tucked in at all times.
- Male cadets will always wear a white T-shirt.
- Shoes will always be shined.
- Black socks will be worn with the khaki and dress blue uniform. White dress socks will be worn with the tropical uniform.
- Uniforms will be clean and free of wrinkles.
- All brass will be shined and properly displayed.
- Male cadets will be clean shaven. Sideburns will not extend past the middle of the ear. Hair will be no longer than three inches on top and not touching the ears. The scalp may not be shaved; and eccentric haircuts are not authorized.
- Female cadets will wear their hair as to not interfere with the proper wear of their covers. Hair shall not extend below the base of the collar.
- Necklaces of religious origin may be worn but cannot show while in uniform. Females may not have more than one earring in each ear. Earrings must

Aggie Code of Honor: Aggies do not lie, cheat or steal, nor tolerate those who do.

be of the stud type. Male cadets are not authorized to wear earrings while in uniform.

- Sunglasses with the “Granny straps” are not authorized. Sunglasses will be of a solid color, such as gold, silver, or black (no neon colors). Sunglass lenses should be dark green, smoke or black –no mirror or multi-colored lenses) Navy aviator sunglasses are recommended. Sunglasses may not be worn in formations or inspections.
- Cadet uniforms shall not be odoriferous in any way and maintained in good repair.
- Only dark blue (NROTC) or Black backpacks are permitted but will be worn not carried. Brief cases are permitted.
- Blue Jump suit will not be worn on campus; except in a few authorized areas and the ship. The blue jump suit will not be worn in formation, mess hall , classrooms or the Library!

Aggie Code of Honor: Aggies do not lie, cheat or steal, nor tolerate those who do.

SEAMANSHIP—KNOTS



Overhand



Figure of eight



Sheet bend or weaver's knot



Square knot

Aggie Code of Honor: Aggies do not lie, cheat or steal, nor tolerate those who do.

SEAMANSHIP—KNOTS

Knots used to form one or more loops



Bowline



Running bowline



Bowline on a bight



French bowline

Knots used to secure an end to a spar



Clove hitch



Timber hitch



Two half hitches

Aggie Code of Honor: Aggies do not lie, cheat or steal, nor tolerate those who do.

SEAMANSHIP—LIFEBOATS

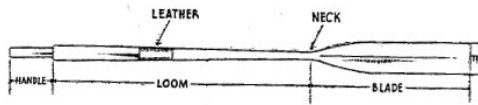

Oar Nomenclature
Profile view

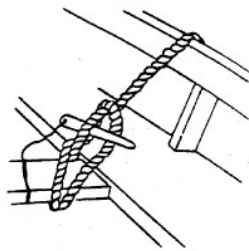

Correctly Rigged Sea Painter

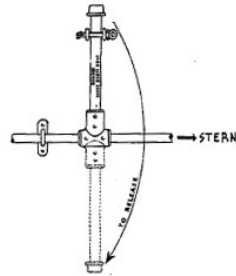

Lifeboat Releasing Lever

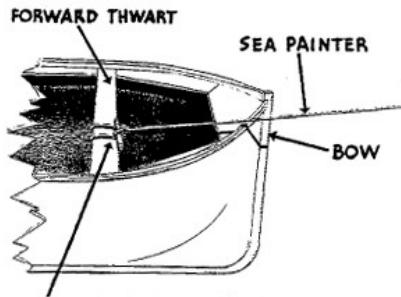

Sea Painter Attachment
Inboard of the Falls & Outboard of everything else

Aggie Code of Honor: Aggies do not lie, cheat or steal, nor tolerate those who do.

SEAMANSHIP—LIFEBOATS

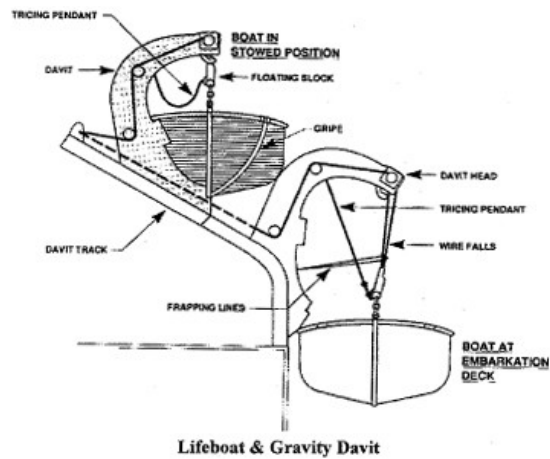
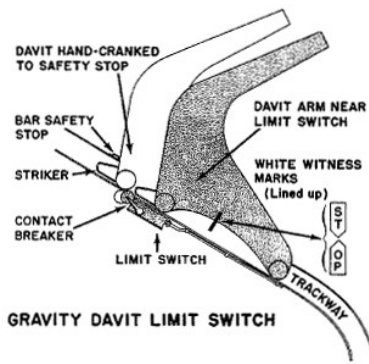

Aggie Code of Honor: Aggies do not lie, cheat or steal, nor tolerate those who do.

SEAMANSHIP—LIFEBOATS

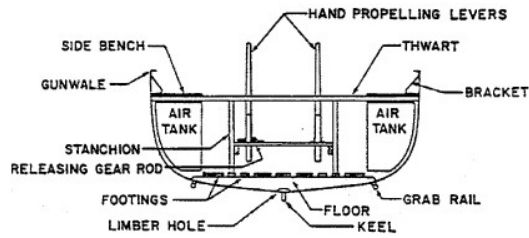

Hand Propelled Lifeboat
Transverse cross section

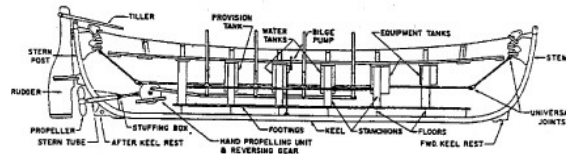

Hand Propelled Lifeboat
Profile view

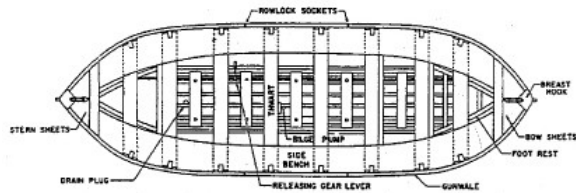

Hand Propelled Lifeboat
View from above

Aggie Code of Honor: Aggies do not lie, cheat or steal, nor tolerate those who do.

SEAMANSHIP—LIFEBOATS

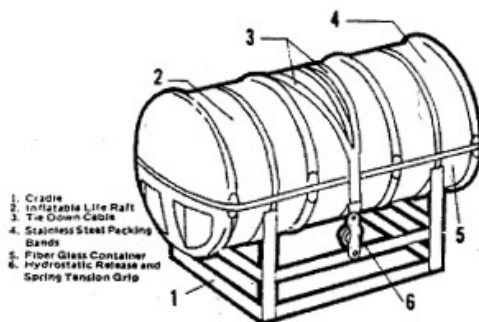

Liferaft Cradle

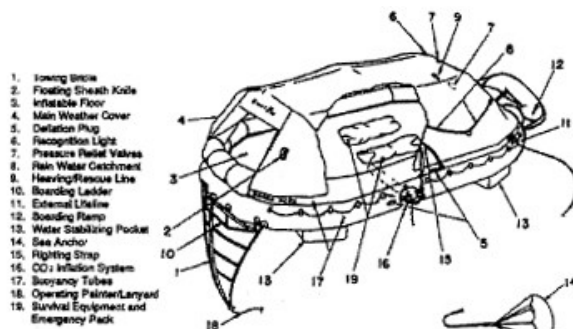

Liferaft Construction

Aggie Code of Honor: Aggies do not lie, cheat or steal, nor tolerate those who do.

SEAMANSHIP—LINES

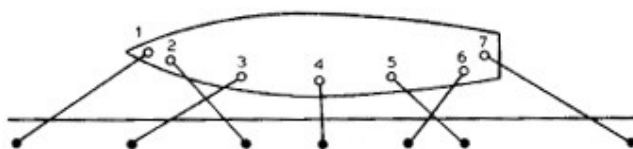

Types of line: (1) Bow line, (2) after bow spring, (3) forward bow spring (4) waist breast, (5) after quarter spring, (6) forward quarter spring, and (7) stern line.

SEAMANSHIP—ANCHOR

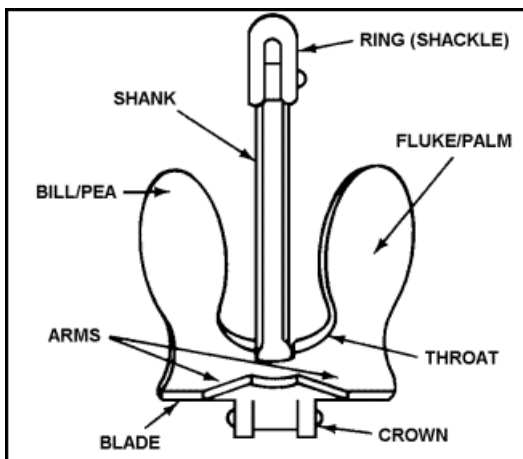

Aggie Code of Honor: Aggies do not lie, cheat or steal, nor tolerate those who do.

SEAMANSHIP—COMPASS ROSE

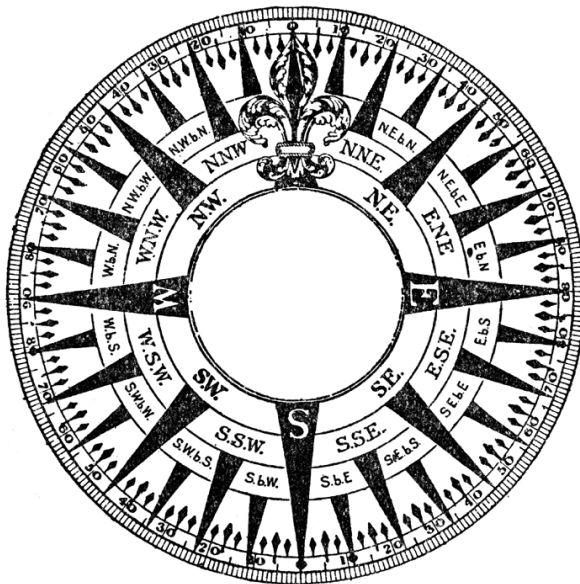

Aggie Code of Honor: Aggies do not lie, cheat or steal, nor tolerate those who do.

SEAMANSHIP—BUNKER GEAR/Self-CONTAINED BREATHING APPARATUS

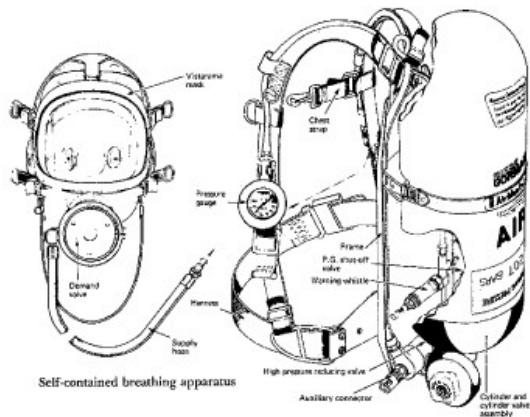

Aggie Code of Honor: Aggies do not lie, cheat or steal, nor tolerate those who do.

SEAMANSHIP—EXTINGUISHERS

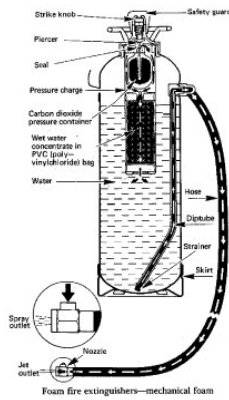
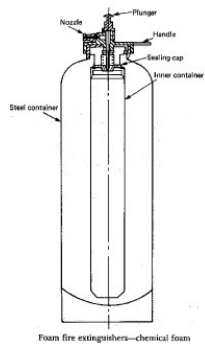

Aggie Code of Honor: Aggies do not lie, cheat or steal, nor tolerate those who do.

SEAMANSHIP—ENGINE EQUIPMENT

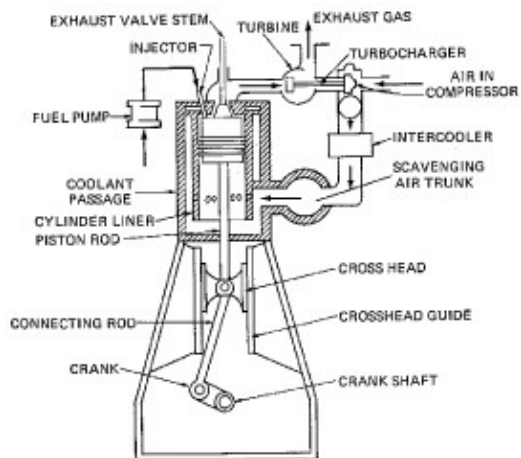

Elements of a typical slow-speed diesel engine.

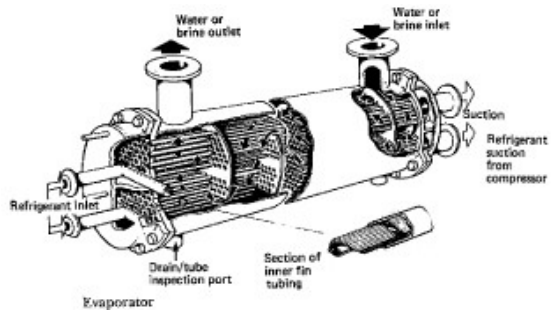

Aggie Code of Honor: Aggies do not lie, cheat or steal, nor tolerate those who do.

SEAMANSHIP—ENGINE EQUIPMENT

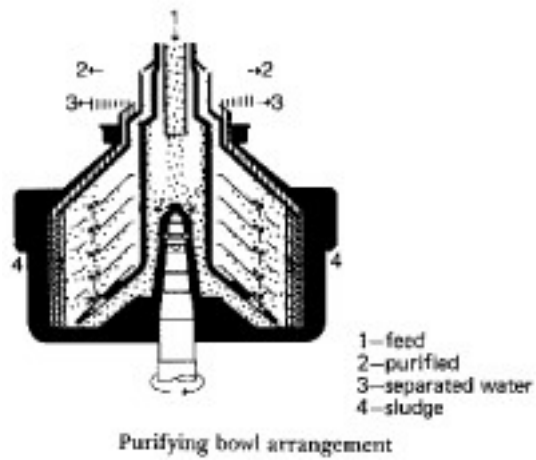
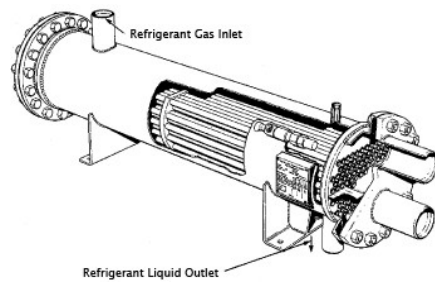

Aggie Code of Honor: Aggies do not lie, cheat or steal, nor tolerate those who do.

SEAMANSHIP—ENGINE EQUIPMENT

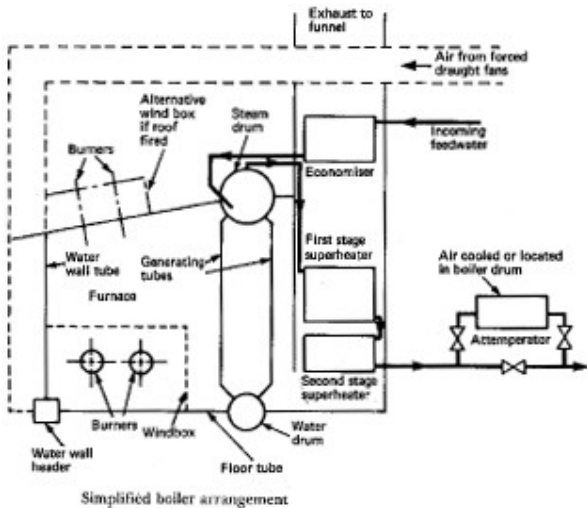

Aggie Code of Honor: Aggies do not lie, cheat or steal, nor tolerate those who do.

SEAMANSHIP—ENGINE EQUIPMENT

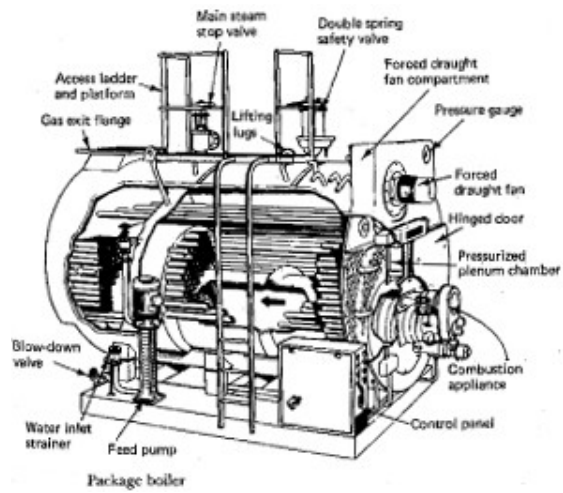

Aggie Code of Honor: Aggies do not lie, cheat or steal, nor tolerate those who do.

SEAMANSHIP—ENGINE EQUIPMENT

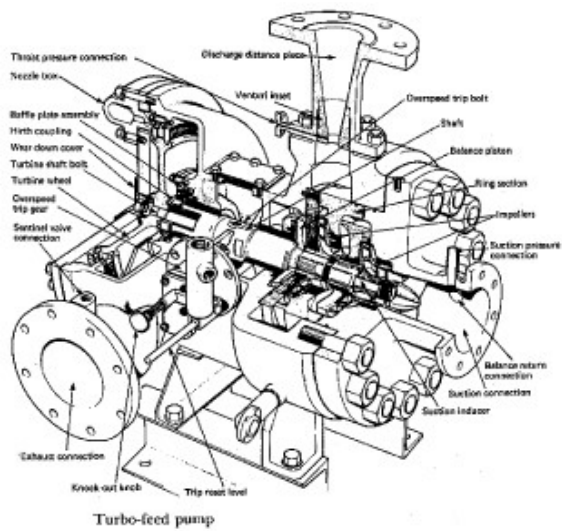

Aggie Code of Honor: Aggies do not lie, cheat or steal, nor tolerate those who do.

SEAMANSHIP—ENGINE EQUIPMENT

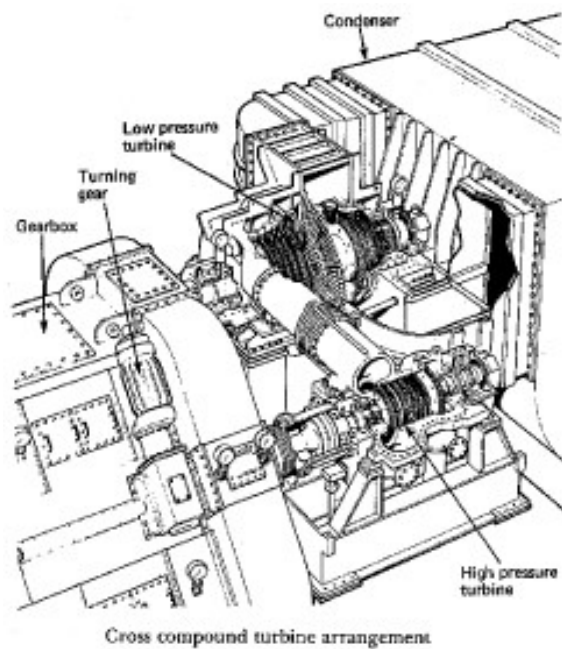

Aggie Code of Honor: Aggies do not lie, cheat or steal, nor tolerate those who do.

SEAMANSHIP—ENGINE EQUIPMENT

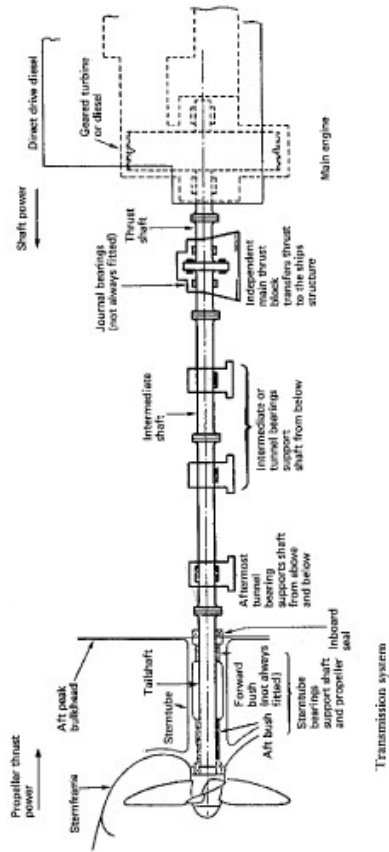

Aggie Code of Honor: Aggies do not lie, cheat or steal, nor tolerate those who do.

SEAMANSHIP—ENGINE EQUIPMENT

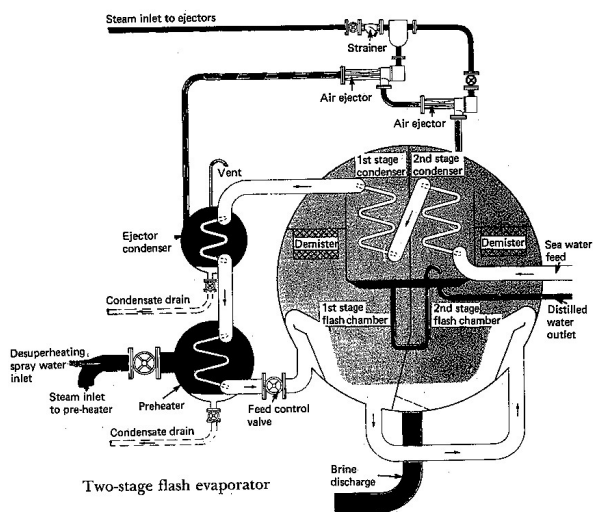

Aggie Code of Honor: Aggies do not lie, cheat or steal, nor tolerate those who do.

SEAMANSHIP—DONT'S

- Never go up and down ladders with both hands full.
- Never work in the hot sun without protecting the head.
- Never walk on the side where cargo is being worked.
- Never walk through unlighted 'tween deck spaces.
- Never walk on weather side of decks in heavy seas.
- Never walk on wet or oily decks with rubber soles or heels.
- Never stand in the bight of an anchor cable or line.
- Never work aloft without a safety belt and line.
- Never use goggles to protect forehead instead of eyes.
- Never enter a gas-filled hold with out a life line.
- Never smoke on deck, on barges, or on the pier when fuel oil is being loaded or discharged.
- Never smoke in the vicinity of open hatches or in cargo holds.
- While cargo lighters are alongside, do not throw lighted matches, cigarettes, etc. over the side or out portholes.

SEA AND SHIPBOARD TERMS

Fore (forward) towards the front of the vessel
Aft (after) towards the rear of the vessel
Bow front part of the vessel
Stern rear part of the vessel
Stem extreme forward part of the bow
Port left side of the vessel, looking forward
Starboard Right side of the vessel looking forward
Below down
Above up
Quarter after part of vessel, to either side
Weather deck any exposed, top deck
Bridge pilothouse or wheel house
Fantail weather deck area around stern
Amidships area halfway between bow and stern
Athwartships side to side
Center line center line of vessel
Inboard towards centerline of vessel
Outboard away from centerline of vessel
Deck floor
Overhead ceiling
Bulkhead wall
Passageway hallway
Ladder stairs or ladder
Superstructure the deckhouse
LOA Length overall
Beam width of vessel
Brow/gangway ramp leading aboard vessel
Quarterdeck area of vessel from which brow leads

Aggie Code of Honor: Aggies do not lie, cheat or steal, nor tolerate those who do.

Berthing a living space

Bunk/rack bed

Head toilet

Stateroom bedroom or cabin

Galley kitchen

Mess dining room

WTD water tight door

FSD fire screen door

Dog mechanical latch to secure hatches

Porthole window

Stack smoke stack

Forecastle "focsle" forward most weather deck of ship, also used to mean a sailor's cabin

Tackle any system of lines and blocks used to perform work

Line a rope used to perform work

Hawser a heavy line for mooring the ship

1 Knot = 1 Nautical Mile / Hour

The old Man Ship's Master

Chief Ship's Chief Engineer

Boatswain "bosun" the experienced seaman who is in charge of the deck work crew

AB able-bodied seaman (a deck rating)

OS ordinary seaman (a deck rating)

QMED Qualified mechanical engineering assistant (an engineering rating)

VESSEL ORIENTATION

Decks begin at top with the flying bridge; and continue to the main deck or weather deck. The main deck is deck "1". All decks above this are prefixed with a "0" (i.e. "01", "02", etc) and are numbered upward or topside. All decks below the main deck are simply numbered "2", "3", etc. moving down or below. On the SS Cape Gibson the decks are as follows:

- Flying Bridge (05)
- Navigating Deck and Wheelhouse (04)
- Bridge Deck (03)
- Passenger Deck (02)
- Upper Deck (01)
- Main or Weather Deck (1)

Most vessels have a framing system for rapid compartment identification and location and is a combination of three (3) separate numbers. The first number identifies the deck on which the compartment is located. The second is the frame number aft of the forward perpendicular, and the third number is the side of the vessel on which the inboard most bulkhead of the compartment is located; the smaller the number, the closer to the centerline of the vessel; the larger the number, the further outboard. Even numbers are located on the port side, and odd on the starboard side. On the SS Cape Gibson frames are numbered from the bow to stern beginning at Frame 0 and running to Frame 245. Most foreign built hulls are numbered aft forward with the deck and side naming conventions remaining the same.

DECK-FRAME-SIDE

Example of a space above the main deck approximately amidships on the starboard side:

01-135-1

Example of a space below the main deck toward the stern on the port side:

2-205-2

Aggie Code of Honor: Aggies do not lie, cheat or steal, nor tolerate those who do.

SHIP'S SPECIFICATIONS

Name USTS Texas Clipper
Owner Maritime Administration
400 7th Street SW
Washington DC 20590
Operator Texas A&M University at Galveston
1001 Texas Clipper Road
Galveston, TX 77554
Built February 1968
Builder Newport News Shipbuilding and Dry Dock
Location Newport News, Virginia
Port of Registry Galveston, Texas
Length Overall 605 feet
Beam 82 feet
Draft 35 feet
Displacement 31,995 long tons
Speed 17.9 knots

- Laid down as Indian Mail for the American Mail Lines (AML). The hull is a Maritime Administration type (C5-S-75a) hull under Maritime Administration contract (MA 216) at Newport News Shipbuilding and Dry Dock Co., Newport News, Virginia.
- Delivered to the Maritime Administration, 13 December 1968, for operation by American Mail Lines.
- Acquired by American President Lines (APL) and renamed the SS President Jackson.
- Reacquired by the Maritime Administration and assignment to the Ready Reserve Fleet (RRF), renamed to SS Cape Gibson.
- Transferred to the Texas Maritime Academy for a Merchant Marine Training Vessel.

Aggie Code of Honor: Aggies do not lie, cheat or steal, nor tolerate those who do.

FACTS & QUOTES

“...Let your watchword be duty, and know no other talisman of success than labor. Let honor be your guiding star in your dealings with your superiors, your fellows, with all. Be true to a trust reposed as the needle to the pole, stand by the right even to the sacrifice of life itself, and learn that death is preferable to dishonor.” —**Governor Richard Coke, addressing students in 1876**

In 1968, Aggies on the TEXAS CLIPPER’s summer cruise brought back a tree from Oslo, Norway which was used for Bonfire center pole.

“The propeller of seagoing tug POINT SUR which served at the invasion of Normandy June 6, 1944, presented by the Dow Chemical company to Texas A&M University at Galveston on March 8, 1984.” —inscription on the propeller of the POINT SUR.

“This anchor serves as a memorial to the T/S TEXAS CLIPPER. She served Texas A&M University at Galveston for 32 years, traveling over a quarter of a million miles visiting 49 foreign ports. Launched on September 12, 1944, at Sparrows Point, Maryland, she served as an attack troop transport in World War II as USS QUEENS. She then sailed for American Export Lines as one of the Four Aces under the name EXCAMBION. In 1965, she arrived at Galveston as the University’s first training ship. Having trained thousands of cadets, T/S TEXAS-CLIPPER will sail in our hearts forever.” —inscription on the anchor of the USTS TEXAS CLIPPER I

733 U.S. cargo ships were lost and over 6,000 United States merchant seamen were killed in shipping raids during World War II. Nearly 600 seamen were held as prisoners of war.

Aggie Code of Honor: Aggies do not lie, cheat or steal, nor tolerate those who do.

IMPORTANT DATES

- 1876 The Agricultural and Mechanical College of Texas, established by the Morrill Land Grant Act, opens for classes on October 4
- 1920 Jones Act establishes the U.S. Merchant Marine for national and economic security
- 1931 The Texas legislature authorizes the establishment of an A&M Nautical School; the Great Depression prevents funding
- 1933 To commemorate the efforts of merchant seaman, the first annual National Maritime Day is observed on May 22
- 1952 Texas A&M Marine Laboratory established
- 1962 Texas Maritime Academy established
- 1965 Training ship TEXAS CLIPPER received
Women officially admitted to A&M
- 1971 A&M designated a Sea Grant College
Moody College of Marine Sciences
Maritime Resources established
- 1979 Board of Regents designates the Mitchell campus as "Texas A&M University at Galveston"
- 1996 TEXAS CLIPPER replaced by TEXAS CLIPPER II
- 2005 TEXAS CLIPPER II replaced by the former USNS Sirius
- 2007 Original TEXAS CLIPPER sunk 17 miles off the coast of Texas to create an artificial reef
- 2009 The former USNS Sirius departed campus in preparation for the arrival of the fourth training vessel
- 2009 SS Cape Gibson arrived at TAMUG on 19 October 2009, at 1300 hrs.

Aggie Code of Honor: Aggies do not lie, cheat or steal, nor tolerate those who do.

TRADITIONS

Tradition sets Texas A&M University apart from other institutions. When Texas A&M was founded in 1876, its students shared a passion for the school while developing a strong camaraderie between themselves. This spirit still exists today at A&M, growing stronger with each new class of Aggies that learns the importance of saying “Howdy”, attending Aggie Muster, participating in Elephant Walk and much more.

The most well-known tradition of Texas A&M is “**Howdy**” a friendly southern greeting that earned Texas A&M a reputation as the friendliest campus in the world. It is how Aggies ensure that no one feels like a stranger. Though the origins are not known, each year “Howdy Week” celebrates the importance and endurance of this tradition.

12th Man was born in 1922 during a football game with Centre College when injuries took a toll on the Aggie reserves. Coach Dana Bible called upon sophomore E. King Gill to suit up in preparation for taking the field. This gesture was more than enough for the Aggie Team. Although Gill did not play in the game, he had accepted the call to help his team. He came to be thought of as the Twelfth Man because he stood ready for duty in the event that the eleven men on the gridiron needed assistance. That spirit of readiness for service, desire to support, and enthusiasm helped kindle a flame of devotion among the entire student body; a spirit that has grown vigorously throughout the years. The entire student body at A&M is the Twelfth Man, and they stand during the entire game to show their support. The 12th Man is always in the stands waiting to be called upon if they are needed.

Aggie Muster honors Aggies who have died since the last Muster ceremony the previous year and is one of Texas A&M University's most solemn and visible traditions. No matter where Aggies are, no matter in what

Aggie Code of Honor: Aggies do not lie, cheat or steal, nor tolerate those who do.

state or foreign country, whether they are as few as two or as many as the thousands who gather on the Texas A&M campus, they come together each April 21 for Muster. Muster was first held on June 26, 1883. Former students of Texas A&M - then called ex-cadets - were called to gather so they might "...live over again our college days, the victories and defeats won and lost upon drill ground and classroom. Let every alumnus answer a roll call."

Reveille, the first lady of Aggieland, is the official mascot of Texas A&M University. She is the highest ranking member of the Corps of Cadets— a Five-Star General. The current first lady of Aggieland is Reveille VIII who was instated during the summer of 2008.

Reveille I came to Texas A&M in January 1931. A group of cadets picked up a small black and white dog on their way back from Navasota. They brought her back to school so they could care for her. The next morning, when "Reveille" was blown by a bugler, she started barking. She was named after this morning wakeup call. The following football season she was named the official mascot when she led the band onto the field during their half-time performance. When Reveille I died on January 18, 1944, she was given a formal military funeral on the gridiron of Kyle Field. She was then buried at the north entrance to the field, as all Reveilles are, facing the scoreboard so that she can watch the Aggies outscore their opponents.

The **Aggie Ring**, worn by Aggie seniors since 1894 is recognizable by its distinct design. It easily distinguishes Aggies throughout the world. There are 31 stars on the Aggie Ring including the person wearing it.

Elephant Walk, started in 1922, marks the end of the usefulness of the Aggie seniors to the student body. Like dying elephants, which wander the jungle looking for a place to die after their value to the herd is over, seniors will join hands and wander aimlessly about

Aggie Code of Honor: Aggies do not lie, cheat or steal, nor tolerate those who do.

campus visiting landmarks for the symbolic "last time." Seniors meet for a yell practice and are then led by senior yell leaders through campus. This Aggie tradition is known to underclassmen as "E-Walk" since it is poor form for underclassmen to say the word elephant as it is classified as a "senior word."

Silver Taps is that final tribute paid to an Aggie who, at the time of his death, was enrolled in graduate or undergraduate courses at Texas A&M. It began in 1898 when the first Silver Taps was held in honor of Lawrence Sullivan Ross. Over time, new traditions have been added to Silver Taps. In the 1920's, the flag was placed at half-staff the day of Silver Taps. The special music "Silver Taps," composed by Colonel Richard J. Dunn, was played by two buglers during the 1930's. This haunting arrangement is not formally written; it is passed from bugler to bugler. Formerly, Silver Taps was observed as soon as possible after the death of an Aggie.

Big Event is the nation's largest one-day, student run community service project in the nation. Originally started in College Station in 1982, it was a way for the University to give something back to the community that is so supportive. This Aggie Tradition was started in Galveston in 1994. In 2009, the Galveston Big Event focused on recovery and re-beautification projects across the island as a result of Hurricane Ike.

Midnight Yell began as a post dinner activity in 1913, when different corps companies would gather together to "learn heartily the old time pep." However, it was not until 1931, that Yell Practice as it is known today was held before the t.u. game.

Midnight Yell is held in Galveston on the night before Midnight Yell is held in College Station at Kyle Field, which is the night before any home game. Galveston's Midnight Yell is typically held on Thursday, with the main Aggieland Midnight Yell being held on Friday. The

Aggie Code of Honor: Aggies do not lie, cheat or steal, nor tolerate those who do.

yell leaders lead the crowd in old army yells, the singing of the fight song, and tell fables of how the Aggies are going to beat the everlivin' hell out of our opponent for the next day.

The purpose of Midnight Yell is to pump up the Twelfth Man for the next day's big game. Midnight Yell is led by each school's **Yell Leaders**. Although nationally known for their spirit, the Texas Aggies have no cheerleaders. This is because they have no school cheers. Instead, there are a variety of school yells used by the 12th Man team in support of the team on the field or court. In the Spring of each year, five students (three juniors and two seniors) are elected by the Galveston student body to serve as Campus Yell Leaders for TAMUG.

New Galveston students whose first semester is in the fall are invited to participate in **S.A.L.T. Camp**, a three-day camp introducing new Aggies to their peers and teaching them about TAMUG traditions and yells.

The Anchor serves as a memorial to USTS TEXAS CLIPPER. She served Texas A&M University at Galveston for 32 years, traveling over a quarter of a million miles visiting 49 foreign ports. Students can often be seen rubbing the anchor for good luck before exams. Seniors are the only students permitted to walk between the anchor and the anchor chain.

One of the most visible traditions at the Galveston campus is an unwritten one. The Texas Maritime Academy standard of excellence in maritime training is one of the longest-standing traditions at TAMUG. The TMA Cadet Battalion boasts strong camaraderie, fed by their modest numbers, leadership training and team-building. Summer Cruise is our chance to utilize classroom knowledge in real shipboard situations, and offers us an unparalleled opportunity to see the world. Additionally, activities like the required Firefighter's Training School, which offers cadets a first real taste of the challenges of being a ship's officer, have become traditions in them-

Aggie Code of Honor: Aggies do not lie, cheat or steal, nor tolerate those who do.

selves.

Since 1962, Aggie mariners have been know as among the most professional in the industry. That tradition of excellence is reflected in the quality of our instructors, the difficulty of our curricula and the hands-on nature of our training.

We take pride in our work and in being Aggies.

Aggie Code of Honor: Aggies do not lie, cheat or steal, nor tolerate those who do.

SONGS

The Aggie War Hymn

(J.V. "Pinky" Wilson)

Hullabaloo, Caneck Caneck!

Hullabaloo, Caneck Caneck!

(Verse 1 - traditionally omitted)

All hail to dear old Texas A and M,

Rally around Maroon and White;

Good luck to dear old Texas Aggies,

They are the boys who show the real old Fight.

That good old Aggie spirit thrills us

And makes us yell and yell and yell;

So let's fight for dear old Texas A and M,

We're goin' to beat you all to

Chig-ga-roo-ga-rem! Chig-ga-roo-ga-rem!

Rough! Tough! Real Stuff! Texas A&M,

(Verse 2)

Goodbye to texas university,

So long to the orange and the white.

Good luck to dear old Texas Aggies,

They are the boys that show the real old fight.

"The eyes of Texas are upon you";

that is the song they sing so well....

Sounds like hell!

So good-bye to texas university

We're goin' to beat you all to

Chig-ga-roo-ga-rem! Chig-ga-roo-ga-rem!

Rough! Tough! Real Stuff! Texas A&M,

Saw Varsity's Horns Off

(traditionally sung after the War Hymn)

Saw Varsity's horns off, Saw Varsity's horns off!

Saw Varsity's horns off—short! A!

Varsity's horns are sawed off,

Varsity's horns are sawed off!

Varsity's horns are sawed off—short! A!

Aggie Code of Honor: Aggies do not lie, cheat or steal, nor tolerate those who do.

The Spirit of Aggieland
(Marvin Mimms/Richard Dunn)

(Verse 1)

Some may boast of prowess bold,
of the school they think so grand,
but there's a spirit can ne'er be told,
it's the Spirit of Aggieland.

(Chorus)

We are the Aggies, the Aggies are we,
True to each other as Aggies can be.
We've got to FIGHT, boys,
We've got to fight!
We've got to fight for Maroon and White!
After they've boosted all the rest,
Then they will come and join the best,
For we are the Aggies, the Aggies are we,
We're from Texas A M C.

Verse 2 (traditionally omitted)

Though from alma mater so far I roam,
My whole heart shall be with you e'er;
I'll always be proud to call you my own,
It's the Aggieland so fair.

(Chorus)

Aggie Code of Honor: Aggies do not lie, cheat or steal, nor tolerate those who do.

(Yell)

T,E,X-A-S! A,G,G-I-E!

Fight! Fight! Fight-Fight-Fight!

Fight! Maroon! And White-White-White!

A,G,G-I-E!

Texas! Texas! A-M-C!

Gig'em, Aggies, 1-2-3!

Farmers fight! Farmers fight! Farmers, Farmers, Fight!

The Twelfth Man

(Lil Munnerlyn)

Texas Aggies down in Aggieland

We've got Aggie spirit to a man!

Stand united! That's the Aggie theme,

We're the twelfth man on the team.

When we're down, the going's rough and tough

We just grin and yell we've got the stuff

To fight together for the Aggie dream,

We're the twelfth man on that

FIGHTIN' AGGIE TEAM!

Aggie Code of Honor: Aggies do not lie, cheat or steal, nor tolerate those who do.

YELLS

Aggies don't cheer...we yell!

Gig'em

Aaaaaayyyy, Gig'em, Aggies!

Aggies

A-G-G-I-E-S

A-G-G-I-E-S

Aaaaaayyyyy, Fight'em Aggies!

Farmers Fight

Farmers Fight!

Farmers Fight!

Fight! Fight!

Farmers, Farmers, Fight!

Beat the Hell

Beat the hell outta (insert name of hapless team here)!

Military

Squads left! Squads right!

Farmers, Farmers, we're alright!

Load, ready, aim, fire, BOOM!

A&M! Give us room!

Old Army

A... R... M... Y...

T... A... M... C...

Aaaaaaaayyyyyy

Old Army Fight!

Aggie Code of Honor: Aggies do not lie, cheat or steal, nor tolerate those who do.

Fifteen

Rah! Rah! Rah! Team!

For Team

A-R-M-Y

Yea Army! Fight 'em!

Horse Laugh

Riffety Riffety Riff Raff

Chiffety Chiffety Chiff Chaff

Riff Raff Chiff Chaff

Let's give 'em the horse laugh!

Bus Driver

Sit down, bus driver!

Locomotive

Rah.. Rah.. Rah.. T.. A.. M.. C..

Rah, Rah, Rah, Rah, T, A, M, C,

Rah! Rah! Rah! Rah! T! A! M! C!

Aaaaaaaaaaaaaaaaa

Rah! Rah! Rah! Team!

Aggie Code of Honor: Aggies do not lie, cheat or steal, nor tolerate those who do.

CHARLIE NOBLE

In the days of wooden ships the Charlie Noble (sometimes spelled Charley Noble) was the name for the galley chimney which carried heat from the galley above deck to the ocean breeze. Because of the danger that sparks and hot embers presented to wooden ships, the ship's cook had the responsibility of cleaning the Charlie Noble and ensuring it was free of soot and tar. Traditionally, the cook would fire a pistol up the pipe to loosen the soot. This was called shooting the Charlie Noble.

The Charlie had to be cleaned and refreshed periodically for the safety of all on board. This was and is true of many of the fixtures on a ship. In many ways each person on a ship has responsibility for shooting the Charlie Noble, be it ensuring that fire equipment is working properly or that lines are not frayed or that the bilge pump is working properly.

Shooting the Charlie Noble figuratively means doing all the things necessary to keep a ship and all the souls on board safe.

Aggie Code of Honor: Aggies do not lie, cheat or steal, nor tolerate those who do.

NOTES

Revised August 20, 2010



Aggie Code of Honor: Aggies do not lie, cheat or steal, nor tolerate those who do.





Aggie Code of Honor: Aggies do not lie, cheat or steal, nor tolerate those who do.



Aggie Code of Honor: Aggies do not lie, cheat or steal, nor tolerate those who do.

